

材質/MATERIAL			一般公差	
數量/QUANTITY	Q'TY	S/P	TOTAL	尺寸範圍
加工精度/PROCESS	+		=	容許誤差
表面處理/TREATMENT	~			1-4mm ±0.05mm
備註/NOTE	無			4-16mm ±0.07mm
				16-63mm ±0.1mm
				63-250mm ±0.2mm
				250-1000mm ±0.3mm
				1000-1500mm ±0.5mm

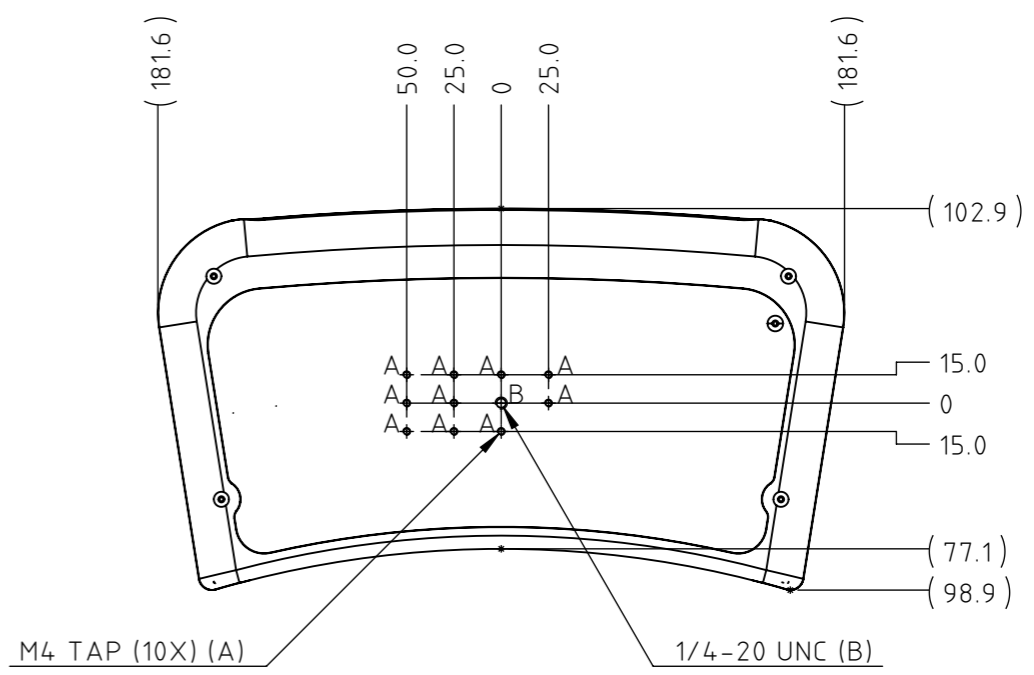
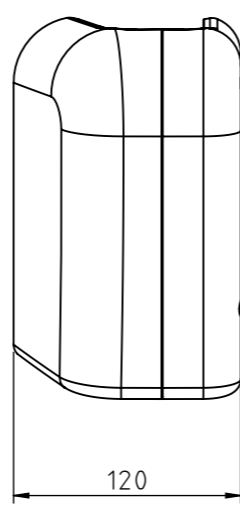
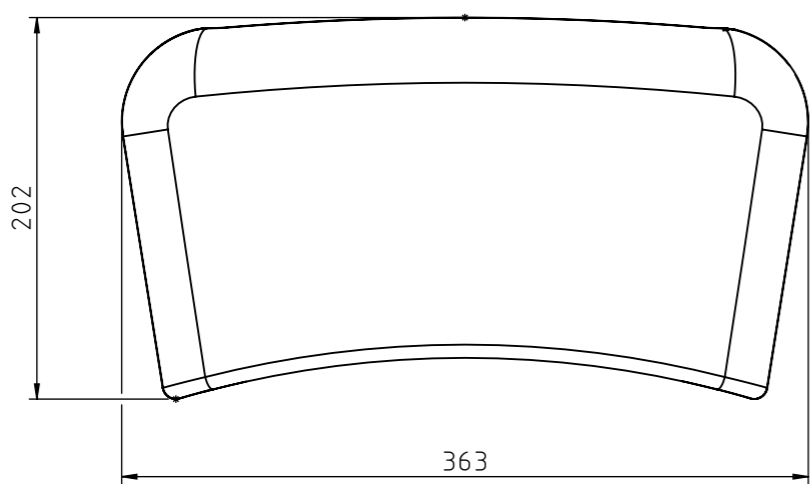
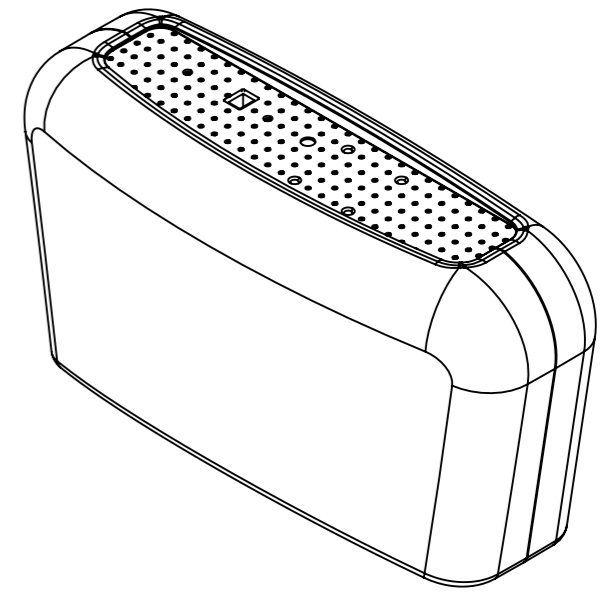
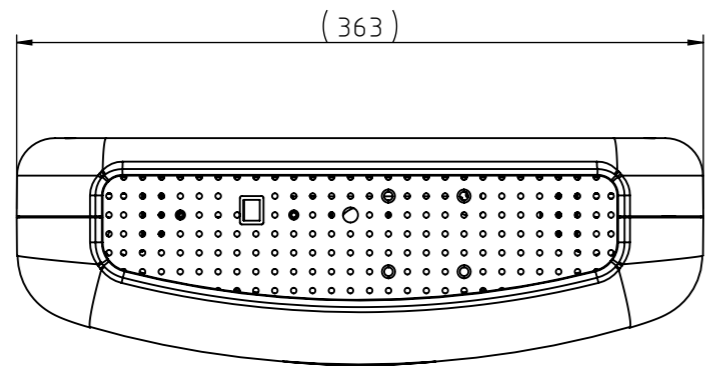

設計/DESIGNER	REMOVE ALL SHARP EDGE () 0.1 X 45° () 0.5 X 45° () 0.3 X 45°		SOLOMON			
Jerry Chen	比例/SCALE	1:4				
繪圖/DRAWER	單位/UNIT	mm	圖號 DWG NO	18010-00-001-0	專案號碼 PROJECT	DEMO1805001
核准/APPROVED			圖名 TITLE	RBP	日期 DATE	2019/1/23
					SHEET 1 / 1	